



PSL Assemblies Ltd
Eastern Avenue
Dunstable
Bedfordshire
LU5 4JY



Tel: +44 (0) 1582 676800
Fax: +44 (0) 1582 676801
email: info@psl-group.uk.com

TECHNICAL SPECIFICATION

ISOLATOR : PRODUCT CODE : ISO50/35

Electrical Properties

Voltage Rating (V_M) 10600V
Voltage Rating(RMS) 4180V

Thermal Properties

Max case temperature 150°C
Operating Temperature -40°C....150°C
Storage Temperature -40°C....150°C
 R_{thCK} 0.01 °C/W
 R_{thC-C} 0.146 °C/W

Mechanical Properties

Materials Aluminium Oxide
Aluminium Nitride
Copper
Max Force 45 kN
Weight 430 g

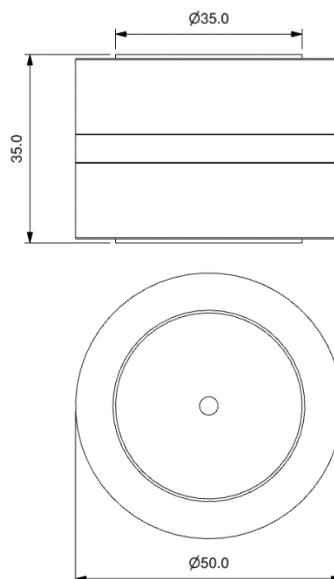

This product and related information remains the intellectual property of PSL Assemblies Limited and its' associated companies. All rights reserved.